

- GB** Attention: for repairs or replacement of parts for maintenance, the "CE" mark is guaranteed only if original spare parts provided by the manufacturer are used.
Silca guarantees supplies of the listed spare parts for 7 years from the date the product is discontinued.
- I** Attenzione: in caso di riparazioni o sostituzione di pezzi per manutenzione, la marcatura "CE" è garantita solo se vengono utilizzate parti di ricambio originali fornite dal costruttore.
Silca garantisce la fornitura dei ricambi presenti nella lista ricambi per 7 anni dalla data di discontinuazione del prodotto.
- D** Achtung: bei Reparaturen oder Auswechseln von Teilen zur Instandhaltung wird die CE-Markierung nur bei Verwendung von vom Hersteller gelieferten Originalersatzteilen gewährleistet.
Silca garantiert für sieben Jahre nach auslauf des Produkts die Lieferung der in der ersatzteilliste enthaltenen ersatzteile.
- F** Attention: si vous effectuez des réparations ou que vous remplacez des pièces pendant un entretien, le marquage "CE" n'est garanti que si vous utilisez des pièces de rechange originales fournies par le fabricant.
Silca garantit la fourniture de pièces de rechange se trouvant dans la liste pendant 7 ans après le mise hors production du produit.
- E** Atención: en caso de reparaciones o sustituciones de las piezas por mantenimiento, se garantiza la marca "CE" sólo si se utilizan partes de repuesto originales suministradas por el constructor.
Silca garantiza el suministro de los repuestos que están en la lista repuestos durante 7 años a partir de la fecha de interrupción producción del producto.
- P** Atenção: em caso de reparações ou substituição de peças para manutenção, a marcação "CE" é garantida exclusivamente se forem utilizadas peças de origem fornecidas pelo fabricante.
A Silca garante o fornecimento das peças de reposição indicadas na lista própria para um período de 7 anos a partir da data em que deixar de fabricar o produto.
- NL** Opgelet: Bij herstellingen of vervanging van onderdelen ten gevolge van onderhoud, blijft de "CE-markering" enkel geldig bij gebruik van originele vervangstukken, geleverd door de fabrikant.
Silca garandeert de levering van de vervangstukken vermeld op de lijst met vervangstukken gedurende 7 jaar na de datum van productonderbreking.

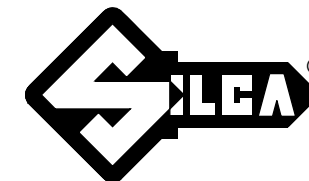

Triax QUATTRO

230V - 50Hz



SILCA S.p.A.
Via Podgora, 20 (Z.I.)
31029 VITTORIO VENETO (TV)
Tel. +39 0438 9136 Fax +39 0438 913800
E-mail: silca@silca.it
www.silca.biz

In the United Kingdom
SILCA Ltd.
6 Lloyds Court, Manor Royal
CRAWLEY RH10 9QU
Tel. +44 1293 531134
Fax +44 1293 531108
E-mail: sales@silcald.co.uk
www.silcald.co.uk

In Germany
SILCA GmbH
Siemensstrasse, 33
42551 VELBERT
Tel. +49 2051 2710
Fax +49 2051 271172
E-mail: info@silca.de
www.silca.de

In France
SILCA S.A.S.
12 Rue de Rouen
Z.I. Limay - Porcheville
78440 PORCHEVILLE
Tel. +33 1 30983500
Fax +33 1 30983501
E-mail: info@silca.fr
www.silca.fr

In Spain
SILCA KEY SYSTEMS S.A.
C/Santander 73A
08020 BARCELONA
Tel. +34 93 4981400
Fax +34 93 2788004
E-mail: silca@silca.es
www.silca.es

In the Netherlands
H. CILLEKENS & ZN. BV
Metaalweg, 4
6045 JB ROERMOND
Tel. +31 475 325147
Fax +31 475 323640
E-mail: info@hcillekens.nl
www.hcillekens.nl

In India
MINDA SILCA Engineering Ltd.
Plot no.37, Toy City,
GREATER NOIDA (U.P.) - 201308
Tel: +91 9871397630/31
Fax: +91 120 2351301
E-mail: info@mindsilca.in
www.mindsilca.in

Exploded drawing and spare parts list
Disegno esploso e lista dei ricambi
Explosionszeichnung und Ersatzteilliste
Dessin éclaté et liste de rechanges
Despiece y lista de repuestos
Desenho explodido e lista das peças de reposição
Detailtekening en lijst met vervangstukken

GB

IMPORTANT NOTE!

The exploded drawing illustrates all the components of the key-cutting machine. Only those marked with a numerical code are spare parts. All the other components shown in the drawing without numbers are simply illustrative.

I

NOTA IMPORTANTE!

Il disegno esplosivo illustra tutte le componenti costituenti la duplicatrice, solamente quelle contrassegnate da un codice numerico sono da considerarsi ricambi. Tutte le altre componenti non numerate presenti nel disegno hanno valore puramente illustrativo.

D

WICHTIGER HINWEIS!

Auf der Explosionszeichnung sind alle Komponenten der Schlüsselkopiermaschine angegeben; nur die mit einem Nummerncode versehenen sind Ersatzteile. Alle anderen, nicht nummerierten Komponenten in der Explosionszeichnung dienen nur zur Erklärung.

F

REMARQUE IMPORTANTE!

Le dessin éclaté montre toutes les pièces composant la duplicatrice; seules les pièces ayant un code en chiffres sont des pièces de rechange. Toutes les pièces de rechange sans chiffres ont une fonction purement illustrative.

E

¡NOTA IMPORTANTE!

El despiece ilustra todos los componentes que constituyen la duplicadora. Deben considerarse repuestos sólo los que están marcados por un código numérico. Todos los otros componentes no numerados que se encuentran en el diseño tienen un valor puramente ilustrativo.

P

IMPORTANTE!

O desenho explodido ilustra todos os componentes que constituem a máquina duplicadora, mas apenas os marcados por um código numérico devem ser considerados peças de reposição. Todos os demais componentes não numerados presentes no desenho têm um valor simplesmente ilustrativo.

NL

BELANGRIJKE OPMERKING!

De detailtekening illustreert alle onderdelen van de duplicceermachine, maar enkel die met een numerieke code moeten als vervangstukken beschouwd worden. Alle andere niet genummerde onderdelen op de tekening zijn zuiver illustratief.

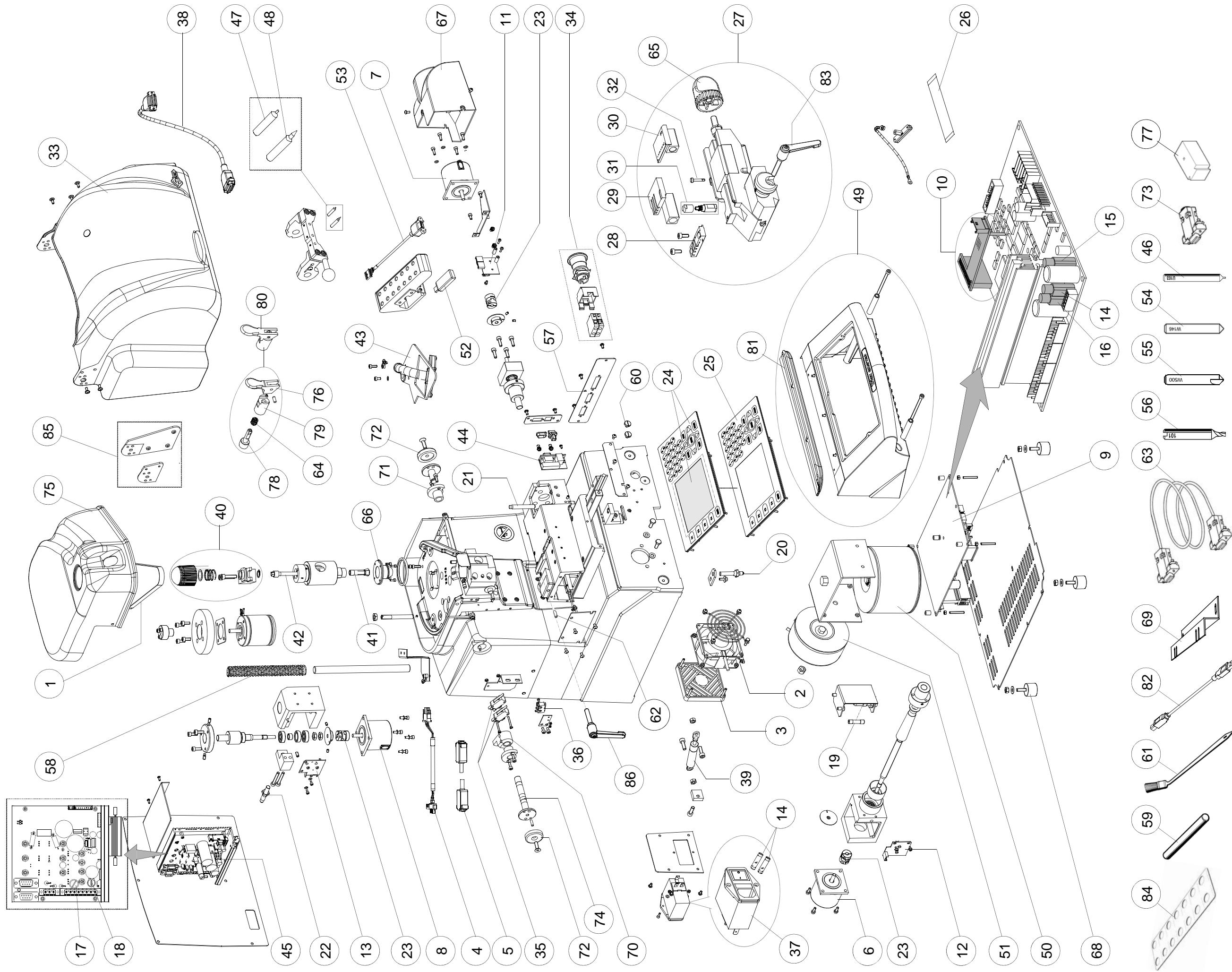

Triax QUATTRO
230V - 50HZ

TRIAx QUATTRO 230V-50Hz

Ref.	Code	I	GB	D	F	E
1	D938511ZR	CINGHIA	BELT	RIEMEN	COURROIE	CORREA
2	D906095ZR	VENTILATORE 230/50	FAN 230/50	VENTILATOR 230/50	VENTILATEUR 230/50	VENTILADOR 230/50
3	D906969ZR	FILTRO VENTILATORE	FILTER FAN	FILTER VENTILATOR	FILTRE VENTILATEUR	FILTRO VENTILADOR
4	D937977ZR	CABLAGGIO MOTORE	MOTOR WIRING	VERKABELUNG MOTOR	CABLAGE MOTEUR	CABLEO MOTOR
5	D937976ZR	CABLAGGIO SENSORI MOTORE	MOTOR SENSORS WIRING	VERKABELUNG SENSOREN MOTOR	CABLAGE SENSEURS MOTEUR	CABLEO SENSORES MOTOR
6	D915085ZR	MOTORE PASSO-PASSO ASSE X	STEP MOTOR X AXIS	SCHRITTMOTOR X-ACHSE	MOTEUR PAS-PAS AXE X	MOTOR PASO-PASO EJE X
7	D915058ZR	MOTORE PASSO-PASSO FOTOC.ASSE Y	STEP MOTOR PHOTOCELL Y AXIS	SCHRITTMOTOR Y-ACHSE	MOTEUR PAS-PAS PHOTOCELL.AXE Y	MOTOR PASO-PASO FOTOCÉL.EJE Y
8	D917701ZR	MOTORE PASSO-PASSO ASSE Z *	STEP MOTOR VERTICAL AXIS *	SCHRITTMOTOR Z-ACHSE*	MOTEUR PAS-PAS AXE VERTICAL*	MOTOR POR GRADOS EJE VERTICAL *
9	D937242ZR	SCHEDA ELETTRONICA	ELECTRONIC BOARD	ELEKTRONISCHE KARTE	CARTE ELECTRONIQUE	TARJETA ELECTRÓNICA
10	D938395ZR	SCHEDA USB	USB CARD	KARTE USB	CARTE USB	TARJETA USB
11	D914917ZR	SCHEDA FOTOCELLULA ASSE Y	CARD WITH PHOTOCELL Y AXIS	MODUL MIT FOTOZELLE Y-ACHSE	CARTE PHOTOCELLULE AXE Y	FICHA CON FOTOCÉLULA EJE Y
12	D917257ZR	SCHEDA FOTOCELLULA CARR.INFERIORE	PHOTOCELL CARD LOWER CARRIAGE	FOTOZELLE MODUL UNTEREN-SCHLITTEN	CARTE PHOTOCELLULE CHARIOT INFER.	FICHA FOTOCÉLULA CARRO INFERIOR
13	D909730ZR	SCHEDA SENSORE ASSE X	SENSOR CARD X AXIS	SENSOR MODUL X-ACHSE	CARTE SENSEUR AXE X	FICHA SENSOR EJE X
14	D908726ZR	FUSIBILI 4 AMP - RITARDATI	FUSES 4 AMPS - DELAYED	SICHERUNGEN 4 AMPERE - TRÄGE	FUSIBLES 4AMP. - RETARDES	FUSIBLES 4 AMPERIOS - RETARDADOS
15	D912423ZR	FUSIBILI 2 AMP - RITARDATI	FUSES 2 AMPS - DELAYED	SICHERUNGEN 2 AMPERE - TRÄGE	FUSIBLES 2 AMP. - RETARDES	FUSIBLES 2 AMPERIOS - RETARDADOS
16	D910652ZR	FUSIBILI 6,3AMP - RITARDATI	FUSES 6,3 AMPS - DELAYED	SICHERUNGEN 6,3 AMPERE - TRÄGE	FUSIBLES 6,3 AMP. RETARDES	FUSIBLES 6,3 AMPERIOS - RETARDADOS
17	D917515ZR	FUSIBILE 8 AMP - RITARDATI	FUSE 8 AMPS-DELAYED	SICHERUNG 8 AMPERE-TRÄGE	FUSIBLE 8 AMPÈRES-RETARDÉE	FUSIBLE 8 AMPERIOS-RETARDADO
18	D909227ZR	FUSIBILE 1 AMP - RITARDATO	FUSE 1 AMP - DELAYED	SICHERUNG 1 AMP - TRÄGE	FUSIBLE 1 AMP - RETARDÉE	FUSIBLE 1 AMP - RETARDADO
19	D904184ZR	FUSIBILI 1,6 AMP - RITARDATI	FUSES 1,6 AMPS - DELAYED	SICHERUNGSSATZ 1,6 AMP TRÄGE	FUSIBLES 1,6 AMP - RETARDES	FUSIBLES 1,6 AMP - RETARDADOS
20	D915059ZR	SENSORE ASSE X + FOTOCELLULA	X AXIS SENSOR + PHOTOCELL	SENSOR X-ACHSE + FOTOZELLE	SENSEUR AXE X + PHOTOCELLULE	SENSOR EJE X + FOTOCÉLULA
21	D914823ZR	SENSORE ASSE Y	SENSOR Y / UPPER AXIS	FÜHLER Y / OBEREN ACHSE	SENSEUR AXE Y / SUPERIEUR	SENSOR EJE Y / SUPERIOR
22	D917702ZR	SENSORE ASSE Z VERTICALE	VERTICAL Z AXIS SENSOR	SENSOR Z-ACHSE	SENSEUR AXE Z VERTICAL	SENSOR EJE Z VERTICAL
23	D914915ZR	GIUNTO ELASTICO	ELASTIC JOINT	STOSSABSORBER	JOINT ELASTIQUE	JUNTA ELÁSTICA
24	D933204ZR	SET DISPLAY-TASTIERA	DISPLAY-KEYBOARD SET	DISPLAY-TASTATURGRUPPE	ENSEMBLE DISPLAY-CLAVIER	CONJUNTO DISPLAY-TECLADO
25	D934954ZR	TASTIERA	KEYBOARD	TASTATUR	CLAVIER	TECLADO
26	D934167ZR	CAVO PIATTO TASTIERA	KEYBOARD CABLE	KABEL TASTATUR	CÂBLE CLAVIER	CABLE TECLADO
27	D734232ZB	MORSETTO R1+ R12 ENGRAVING	CLAMP R1+ R12 ENGRAVING	FRÄS-/GRAVURSPANNBACKE R1+R12	ETAU R1 + R12 GRAVURE	MORDAZA R1+ R12 GRABADOR
28	D917273ZR	GANASCIA FISSA	FIXED JAW	FESTE SPANNBACKE	MÂCHOIRE FIXE	QUIJADA FIJA
29	D933979ZR	GANASCIA MOBILE SX	LEFT MOBILE JAW	LINKE BEWEGLICHER BACKEN	MÂCHOIRE MOBILE GAUCHE	QUIJADA MÓVIL IZQUIERDA
30	D933981ZR	GANASCIA MOBILE DX	RIGHT MOBILE JAW	RECHTE BEWEGLICHER BACKEN	MÂCHOIRE MOBILE DROITE	QUIJADA MÓVIL DERECHA
31	D908681ZR	TESTA DI TARATURA	TOOL SET FOR CALIBRATION	PLÄTTCHENSATZ SPANNBACKE	ENS.UTIL DE CALIBRAGE	CONJUNTO ÚTIL PARA CALIBRACIÓN
32	D909380ZR	PERNO DI TARATURA	SETTING PIN	EICHSTIFTE	PIVOT ÉTALONNAGE	PERNO DE REGULACIÓN
33	D938054ZR	SCHERMO DI PROTEZIONE IN PLEXIGLASS	PLEXIGLASS PROTECTIVE SHIELD	PLEXIGLAS-SCHUTZ	PROTECTION EN PLEXIGLASS	PROTECCIÓN DE PLEXIGLAS
34	D904712ZR	PULSANTE-BLOCCETTO	PUSH BUTTON-SUPPORT	SCHALTER + HALTER QUATTROCODE	BOUTON-POUSSOIR-SUPPORT	BOTÓN-SOPORTE
35	D916707ZR	MICROINTERRUTTORE V-152-1A5	MICROSWITCH	MIKROSCHALTER	MICROINTERRUPTEUR	MICROINTERRUPTOR
36	D918338ZR	MICROINTERRUTTORE SS-5GLT	MICROSWITCH	MICROSCHALTER	MICROINTERRUPTEUR	MICROINTERRUPTOR
37	D910581ZR	SPINA COMPLETA	SET SWITCH+PLUG	SCHALTER+STECKERGRUPPE	ENSEMBLE INTERRUPTEUR+PRISE	CONJUNTO INTERRUPTOR+ENCHUFE
38	D915093ZR	CAVO DI CONNESSIONE ASSE Y	CONNECTION CABLE Y AXIS	ANSCHLUSSKABEL Y-ACHSE	CÂBLE CONNEXION AXE Y	CONEXIÓN CABLE EJE Y
39	D916547ZR	AMMORTIZZATORE	SHOCK ABSORBER	STOSSDÄMPFER	AMORTISSEUR	AMORTIGUADOR
40	D937305ZR	SET MANOPOLA BLOCCAGGIO PINZA	COLLET KNOB	SPANNZANGE-DREHKNOFF	ENS.POIGNEE BLOQUE PINCE	BOTÓN PINZA
41	D937929ZR	PINZA	COLLET	SPANNZANGE	PINCE	PINZA
42	D937937ZR	PERNO DI BLOCCAGGIO	LOCKING PIN	SICHERUNGSTIFT	PIVOT DE BLOCAGE	PERNO DE BLOQUEO
43	D935330ZR	SET LAMPADA LED	LED LAMP	LAMPE LED	LAMPE LED	LÁMPARA LED
44	D934160ZR	SCHEDA USB/SERIALE	USB/SERIAL CARD	KARTE USB/SERIELLE	CARTE USB/SERIELLE	TARJETA USB/SERIAL
45	D937285ZR	SCHEDA AZIONAMENTO MOTORE	MOTOR START-UP CARD	MOTOR START KARTE	CARTE DEMARRAGE MOTEUR	TARJETA PUESTA EN MARCHA MOTOR
46	D911108ZR	TASTATORE/DECODIFICATORE U103	TRACER POINT/DECODER U103	TASTER/DECODIERER U103	PALPEUR/DECODEUR U103	PALPADOR/DESCODIFICADOR U103
47	D917259ZR	TASTATORE CHIAVI LASER U103TT	TRACER POINT FOR LASER KEYS U103TT	TASTER/DECODIERER U103TT	PALPEUR CLES LASER U103TT	PALPADOR DE LLAVES LASER U103TT
48	D917260ZR	TASTATORE CHIAVI PUNZONATE U102TT	TRACER POINT FOR DIMPLE KEYS U102TT	TASTER/DECODIERER U102TT	PALPEUR CLES À POINTS U102TT	PALPADOR DE LLAVES PUNZON. U102TT
49	D938396ZR	SUPPORTO TASTIERA COMPLETO	KEYBOARD SUPPORT	TASTATURHALTERUNG	ENS.SUPPORT CLAVIER	SOPORTE TECLADO COMPLETO
50	D937286ZR	TRASFORMATORE 230/18-36V	TRANSFORMER 230/18-36V	TRANSFORMATOR 230/18-36V	TRANSFORMATEUR 230/18-36V	TRANSFORMADOR 230/18-36V
51	D937289ZR	TRASFORMATORE 230/18-24V	TRANSFORMER 230/18-24V	TRANSFORMATOR 230/18-24V	TRANSFORMATEUR 230/18-24V	TRANSFORMADOR 230/18-24V
52	D937449ZR	USB PEN 1GB	USB PEN 1GB	USB PEN 1GB	USB PEN 1GB	USB PEN 1GB

TRIAx QUATTRO 230V-50Hz

Ref.	Code	I	GB	D	F	E
53	D937253ZR	CABLAGGIO USB PEN	USB PEN WIRING	VERKABELUNG USB PEN	CABLAGE USB PEN	CABLEO USB PEN
54	D734267ZB	FRESINO W146	CUTTER W146	FRÄSER W146	FRAISE W146	FRESA W146
55	D738590ZB	FRESINO W500	CUTTER W500	FRÄSER W500	FRAISE W500	FRESA W500
56	D709238ZB	FRESINO W101	CUTTER W101	FRÄSER W101	FRAISE W101	FRESA W101
57	D937572ZR	PIASTRINA PORTA CONNETTORI	CONNECTORS PLATE	PLÄTTCHEN STECKVERBINDER	PLAQUE POUR CONNECTEURS	PLACA PARA CONECTORES
58	D903137ZR	MOLLA	SPRING	FEDER	RESSORT 0,2X230X2,20 P7,98	MUELLE
59	D904174ZR	SPINA DI TARATURA	SETTING PIN	JUSTIERSTIFT	GOUPILLE D'ETALONNAGE	PERNO DE AJUSTE
60	D906449ZR	VITE TERMINALE	SCREW	SCHRAUBE	VIS TERMINAL CHARIOT	TORNILLO
61	D906935ZR	PENNELLO INCLINATO	SLANTED BRUSH	GEBOGENER PINSEL	PINCEAU INCLINÉ	PINCEL INCLINADO
62	D908753ZR	PASTIGLIA	PAD	TABLET	PASTILLE	PASTILLA
63	D909281ZR	CAVO SERIALE 9/9	SERIAL CABLE	SERIELLE KABEL	CABLE SERIELLE	CABLE SERIAL
64	D910554ZR	MOLLA	SPRING	FEDER	RESSORT	RESORTE
65	D911679ZR	MANOPOLA MORSETTO	JAW HANDLE	SPANNBACKEN-DREHKNOPF	MANETTE DE L'ETAU	RUEDA DE MANO DE LA MORDAZA
66	D912809ZR	SUPPORTO BOCCAGLIO	VACUUM NOZZLE SUPPORT	MUNDUSTÜCK HALTERUNG	SUPPORT TUYAU D'ASPIRATION	SOPORTE BOQUILLA ASPIRACION
67	D914916ZR	CARTER MOTORE P/P	STEP MOTOR SHIELD	SCHRITTMOTORGEHÄUSE	PROTECTION MOTEUR PAS-PAS	CÁRTER MOTOR PASO-PASO
68	D915090ZR	PIEDINO	FOOT	FUSS	PIED	PIE
69	D915098ZR	STAFFA IMBALLO	PACKAGING BRACKET	SPANNEISEN FÜR VERPACKUNG	BRIDE POUR EMBALLAGE	ESTRIBO PARA EMBALAJE
70	D916546ZR	BIELLA X MOLLA	SPRING ROD	PLEUEL FÜR FEDER	BIELLE POUR RESSORT	RÓD PARA RESORTE
71	D916557ZR	GHIERA X PROTEZIONE	PROTECTIVE RING	ZWINGE FÜR SCHUTZ	ANNEAU DE PROTECTION	VÍROLA DE PROTECCION
72	D916558ZR	NOTTOLINO PROTEZIONE ROSSO	RED PROTECTIVE PAWL	KLINKE FÜR SCHUTZ ROT	CLIQUET DE PROTECTION ROUGE	TRINQUETE DE PROTECCION ROJO
73	D916661ZR	SPINA TEST SERIALE Z4	Z4 SERIAL TEST CONNECTOR	TESTSTECKER SERIELLER PORT Z4	CHEVILLE TEST SÉRIE Z4	CLAVIJA TEST SERIAL Z4
74	D938419ZR	PERNO X PROTEZIONE SX	LEFT PROTECTIVE PIN	LINKE STIFT FÜR SCHUTZ	PIVOT GAUCHE DE PROTECTION	PERNO IZQUIERDO DE PROTECCIÓN
75	D938450ZR	CARTER CINGHIA	BELT PROTECTIVE SHIELD	RIEMENGEHÄUSE	PROTECTION COURROIE	CÁRTER CORREA
76	D917027ZR	ECCENTRICO ANTIROTAZIONE	ECCENTRIC GEAR	NOCKEN	CAME ANTI-ROTATION	EXCÉNTRICO ANTI-ROTACIÓN
77	D917274ZR	DIMA Z5 BLOCCHETTO TARATURA	SETTING TEMPLATE Z5	SCHABLONE Z5	GABARIT D'ETALONNAGE Z5	GALIBO DE AJUSTE Z5
78	D917508ZR	PERNO ANTIROTAZIONE	ANTI-ROTATION PIN	ANTI-UMDREHUNG STIFT	PIVOT ANTI-ROTATION	PERNO ANTI-ROTACIÓN
79	D917509ZR	BOCCOLA ANTIROTAZIONE	ANTI-ROTATION BUSH	ANTI-UMDREHUNG BUCHSE	BOUCLE ANTI-ROTATION	BUJE ANTI-ROTACIÓN
80	D917511ZR	LEVA BLOCCA MANDRINO	SPINDLE LOCKING LEVER	SPINDEL SPERRHEBEL	LEVIER BLOCAGE MANDRIN	LEVA BLOQUEO MANDRIL
81	D927442ZR	APPOGGIO CARTER	PROTECTIVE SHIELD SUPPORT	SCHUTZ-UNTERSTÜTZUNG	APPUI POUR PROTECTION	SOPORTE PROTECCIÓN
82	D929095ZR	CAVO USB-USB (A-B)	CABLE USB-USB (A-B)	KABEL USB-USB (A-B)	CÂBLE USB-USB (A-B)	CABLE USB-USB (A-B)
83	D929898ZR	MANIGLIA MORSETTO	CLAMP LEVER/HANDLE	HEBEL/GRIFF SPANNBACKEN	POIGNEE/LEVIER DE L'ÉTAU	MANECILLA/PALANCA DE LA MORDAZA
84	D937255ZR	ETICHETTA ADESIVA FRESE/TASTATORI	ADHESIVE LABEL CUTTERS/TRACERS	KLEBE ETIKETT FRÄSERS/TASTERS	ÉTIQUETTE ADHÉSIVE FRAISES/PALPEURS	ETIQUETA ADHESIVA FRESAS/PALPADORES
85	D938479ZR	KIT STAFFE CARTER	STIRRUPS FOR PROTECTIVE SHIELD	SATZ TRAGBÜGEL FÜR SCHUTZ	ENS.ÉTRIERS POUR PROTECTION	CONJUNTO ESTRIBOS PARA PROTECCIÓN
86	D938624ZR	MANIGLIA BLOCCA MORSETTO	CLAMP LOCKING HANDLE	HANDGRIFF FÜR SPANNBACKE SPERRUNG	POIGNEE DE BLOCAGE ETAU	ABRAZADERA DE BLOQUEO MORDAZA